

ZM AHRV Series

20 VA - 100 VA MULTI CONNECT WIRE AND QUICK CONNECT CLASS 2 UL 1585 TRANSFORMER

FEATURES

- 20VA - 100 VA
- Compact frame size
- 50/60 Hz
- Input voltages 115 - 575 VAC, output 2.5 - 24 V
- Terminations with quick-connect
- Foot-Mount, Panel-Mount, Multimount
- Customization for wire length, color, terminations and other customer requirements
- Internal and external circuit protection
- Split bobbin design
- Class B insulation system 130°C rated
- UL/CUR File E214561



GENERAL DATA

Mounting Options	Foot Mount, Panel-Mount, Bracket Multi Mount Adapter Plate
Quick Connect Options	QW - QC and Wire, Q1-QC One Side, Q2 - QC Both Sides, QT - QC Top
Quick Connect Size	Standard .250" x .032"
Frequency	50/60 Hz
Insulation System	130°C Class B

WIRE LEAD DETAILS

	Voltage	Color	Length(mm)	Strip(mm)
Primary	COM	Black	300	10
	120	White	300	10
	208	Red	300	10
	240	Orange	300	10
	277	Brown	300	10
	480	Black/Red	300	10
	575	Grey	300	10
Secondary	12	Violet	300	10
	24	Blue	300	10
	COM	Yellow	300	10

*Standard wire colors: consult factory for specific wire color and length requirements.

NOTES

Customization allowed for termination and mounting without affecting UL.

AHRV Product Catalog Rev. Date : 12/4/14



ZETTLER Magnetics, Inc.

75 COLUMBIA • ALISO VIEJO, CA 92656 • PHONE: (949) 360-5838 • FAX: (949) 360-5839 • E-MAIL: SALES@ZETTLERMAGNETICS.COM

ZM AHRV Series

20 VA - 100 VA CLASS 2 UL 1585 TRANSFORMER

PART NUMBERING SYSTEM

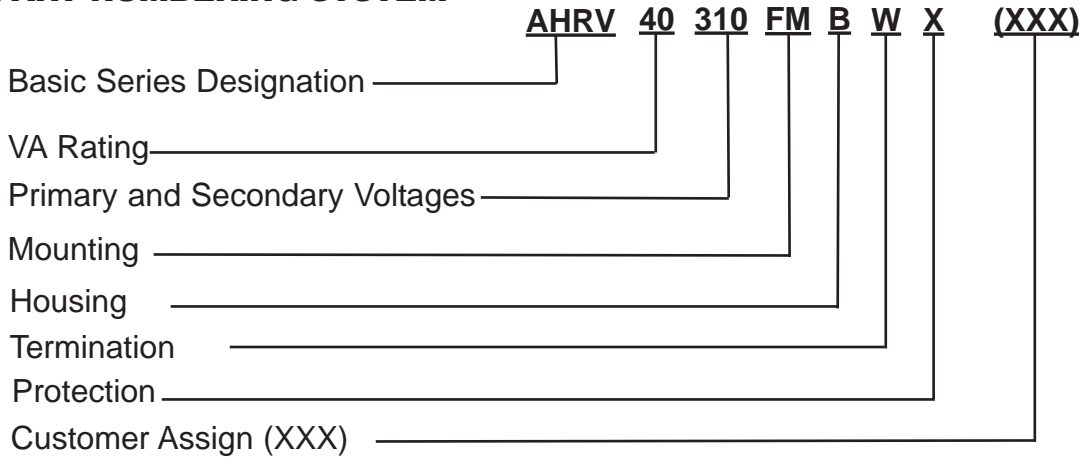

VA RATINGS

Designator	VA
20	20
30	30
40	40
50	50
60	60
75	75
100	96

PRIMARY AND SECONDARY VOLTAGES

Designator	Primary	Secondary	Freq. HZ
309	115	24	50/60
310	208/240	24	50/60
311	120	24	50/60
312	240	24	50/60
313	277	24	50/60
314	480	24	50/60
315	208	24	50/60
316	240/480	24	50/60
317	120/240	24	50/60
318	120/208/240	24	50/60
319	120/208/240/480	24	50/60
320	120/208/240/277	24	50/60
321	120/208/240/277/480	24	50/60
322	208/240/480	24	50/60
323	120	2.5	50/60
324	120	12	50/60
325	208	2.5	50/60
326	208	12	50/60
327	240	2.5	50/60
328	240	12	50/60
329	120/208/240	2.5/12/24	50/60
330	115/208/240	24	50/60
331	120/208	24	50/60
332	120/277	24	50/60
333	120/480	24	50/60
334	208/277	24	50/60
335	208/480	24	50/60
336	240/277	24	50/60
337	277/480	24	50/60
338	120/208/277	24	50/60
339	120/208/480	24	50/60
340	120/240/277	24	50/60
341	120/240/480	24	50/60
342	208/240/277	24	50/60
343	208/277/480	24	50/60

344	240/277/280	24	50/60
345	120/240/277/280	24	50/60
346	575	24	50/60
347	208/240	12/24	50/60
348	120/208/240/480	12/24	50/60
349	115	12/24	50/60
350	208/240	120	50/60
351	230	120	50/60
352	460	120	50/60
353	380/415	24	50/60
354	230	24	50/60
355	460	24	50/60
356	277/480	120	50/60
357	347	24	50/60
358	460/575	24	50/60

This is a partial listing only. Consult factory for your specific requirements. All voltage & VA combinations may not be available.

MOUNTING

Designator	Type
FM	Foot Mount
MM	Multi Mount
PM	Panel Mount

HOUSING

Designator	Type
NULL	Open Frame
B	Bell Housing
C	Channel Frame

Protection

Designator	Type
NULL	None
F	External Fuse
X	Circuit Breaker

Termination

Designator	Type
W	Wire Leads
W1	One Side Wire
W2	Both Sides Wire
QW	QC and Wire
Q1	QC One Side
Q2	QC Both Sides
QT	QC Top
*A	Type A
*B	Type B
*C	Type C
*D	Type D
*E	Type E
*SW	Screw and Wire

**50VA, 75VA, 96VA Bell Housing Only. May be combined with other Terminations.*



ZETTLER Magnetics, Inc.

75 COLUMBIA • ALISO VIEJO, CA 92656 • PHONE: (949) 360-5838 • FAX: (949) 360-5839 • E-MAIL: SALES@ZETTLERMAGNETICS.COM

ZM AHRV Series

20 VA CLASS 2 TRANSFORMERS

Type FMW

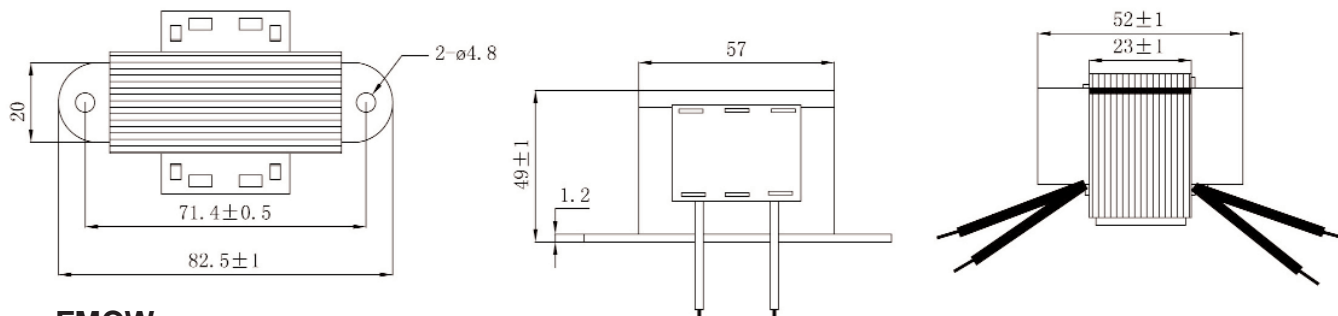

Type FMCW

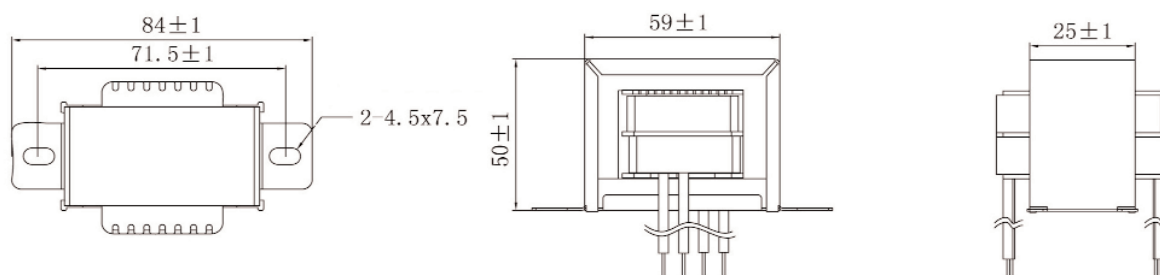

Type FMBQW

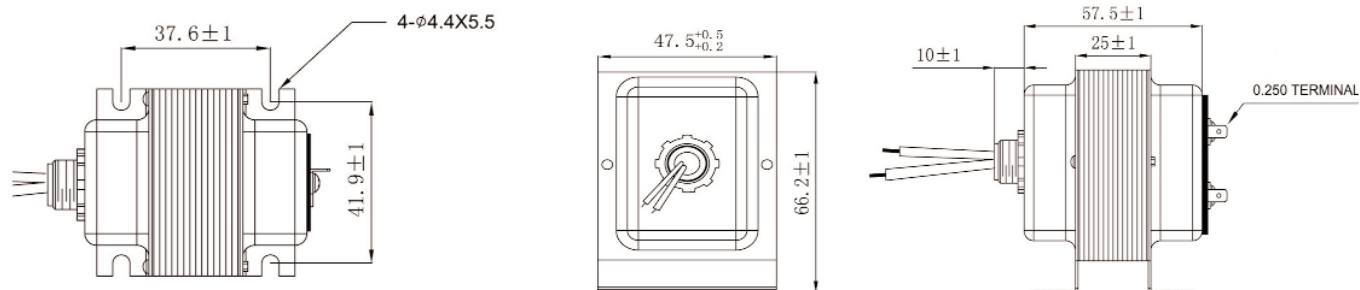

Type MMBW2

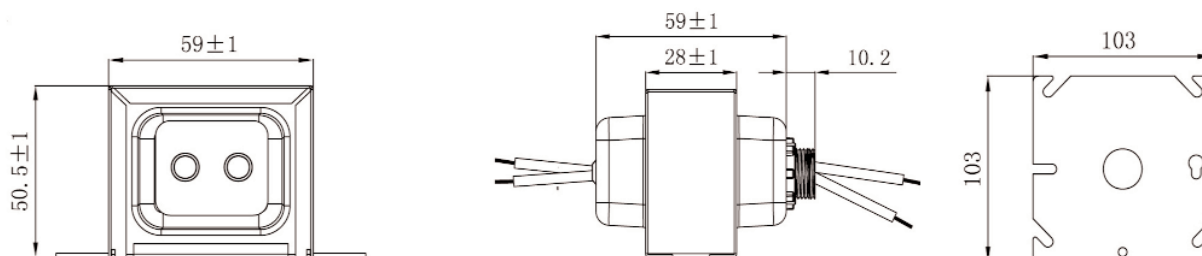

*Contact factory for specific mounting and terminal requirements. Tolerance ± 1mm unless specified otherwise.



ZETTLER Magnetics, Inc.

75 COLUMBIA • ALISO VIEJO, CA 92656 • PHONE: (949) 360-5838 • FAX: (949) 360-5839 • E-MAIL: SALES@ZETTLERMAGNETICS.COM

ZM AHRV Series

30 VA CLASS 2 TRANSFORMERS

Type FMW

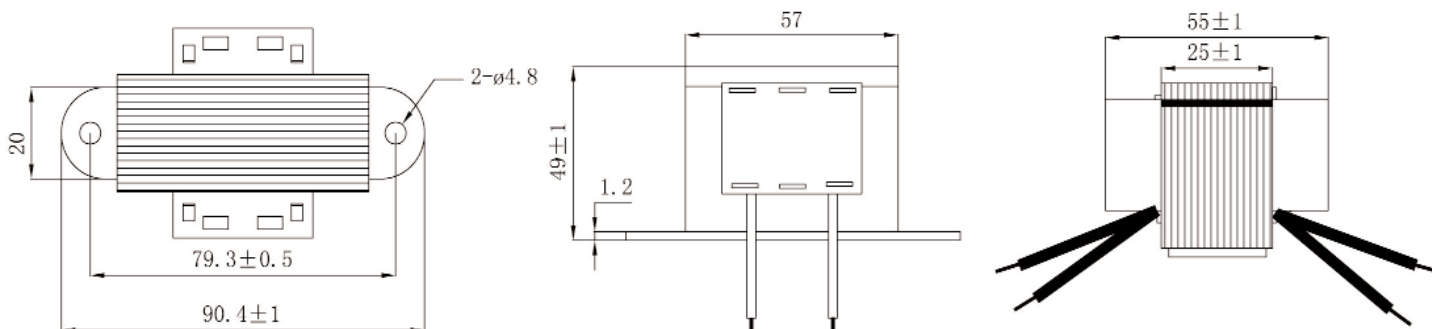

*Contact factory for specific mounting and terminal requirements. Tolerance ± 1mm unless specified otherwise.



ZETTLER *Magnetics, Inc.*

75 COLUMBIA • ALISO VIEJO, CA 92656 • PHONE: (949) 360-5838 • FAX: (949) 360-5839 • E-MAIL: SALES@ZETTLERMAGNETICS.COM

ZM AHRV Series

40 VA CLASS 2 TRANSFORMERS

Type FMW

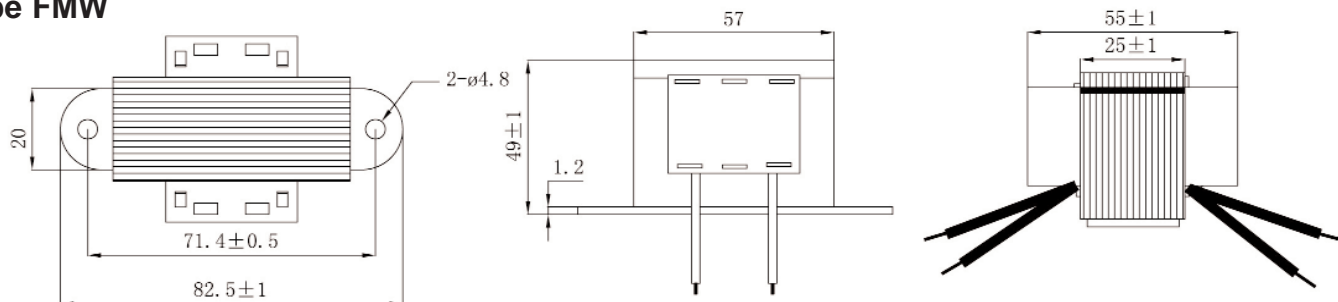

Type FMQ2

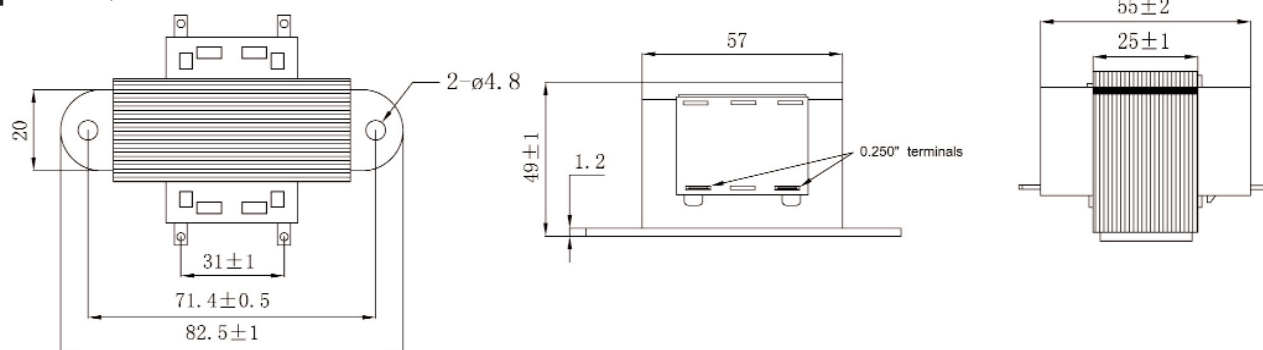

Type FMQT

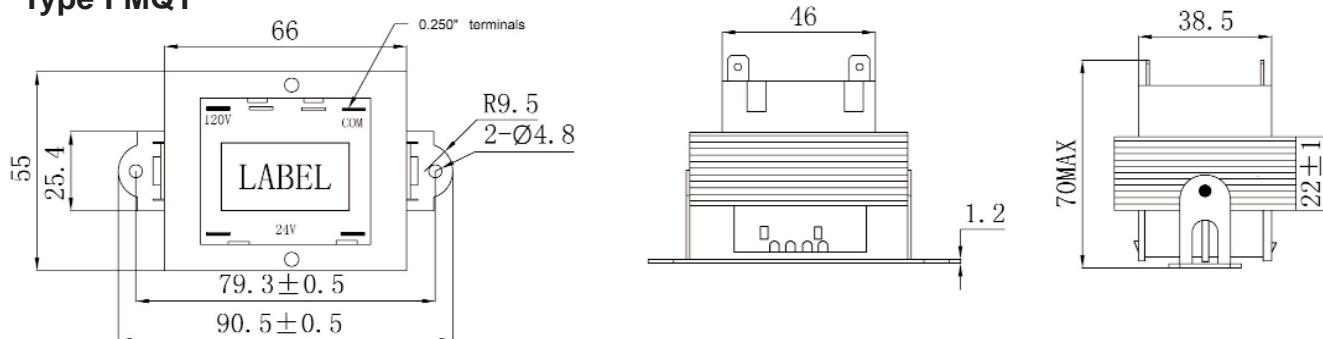

Type FMCW

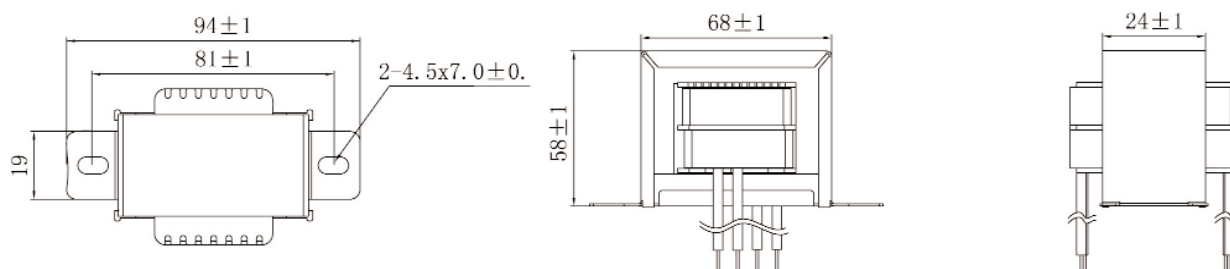

ZETTLER Magnetics, Inc.

75 COLUMBIA • ALISO VIEJO, CA 92656 • PHONE: (949) 360-5838 • FAX: (949) 360-5839 • E-MAIL: SALES@ZETTLERMAGNETICS.COM

ZM AHRV Series

Type FMBW2

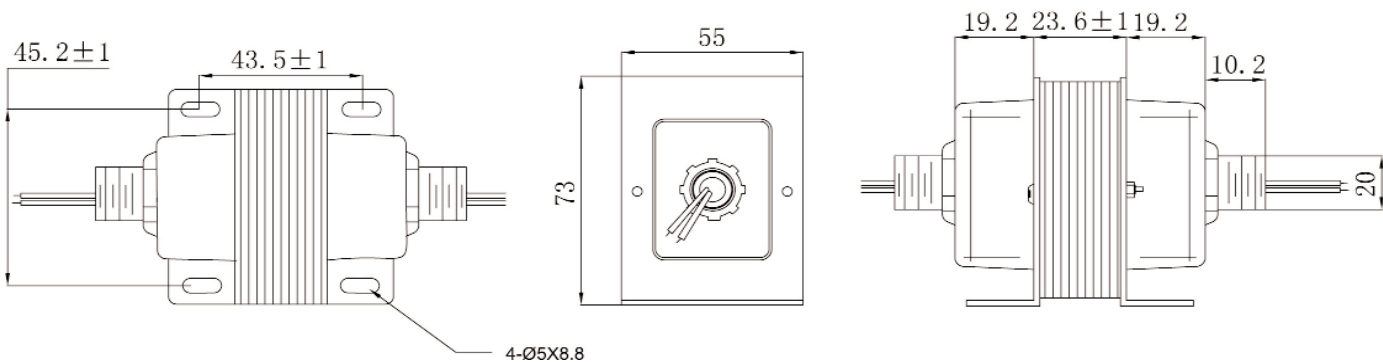

Type MMBW2

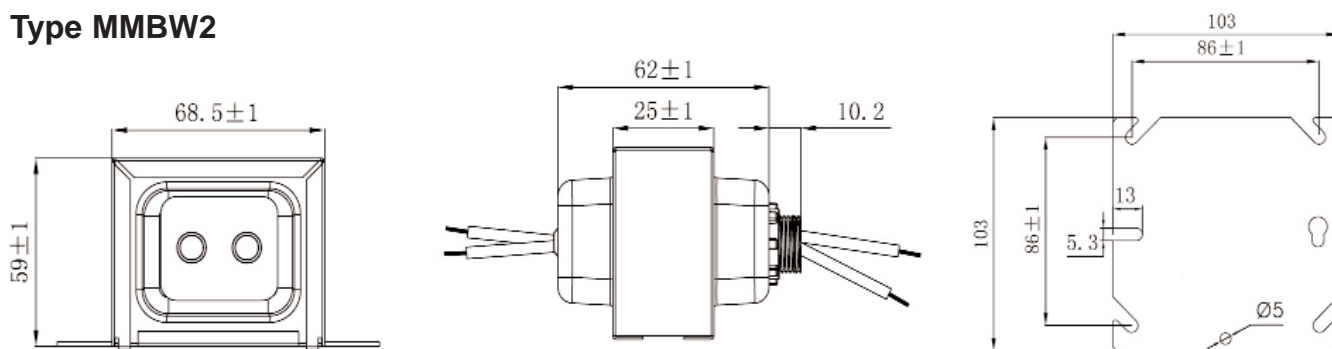

*Contact factory for specific mounting and terminal requirements. Tolerance $\pm 1\text{mm}$ unless specified otherwise.



ZETTLER *Magnetics, Inc.*

75 COLUMBIA • ALISO VIEJO, CA 92656 • PHONE: (949) 360-5838 • FAX: (949) 360-5839 • E-MAIL: SALES@ZETTLERMAGNETICS.COM

ZM AHRV Series

50 VA CLASS 2 TRANSFORMERS

Type FMW

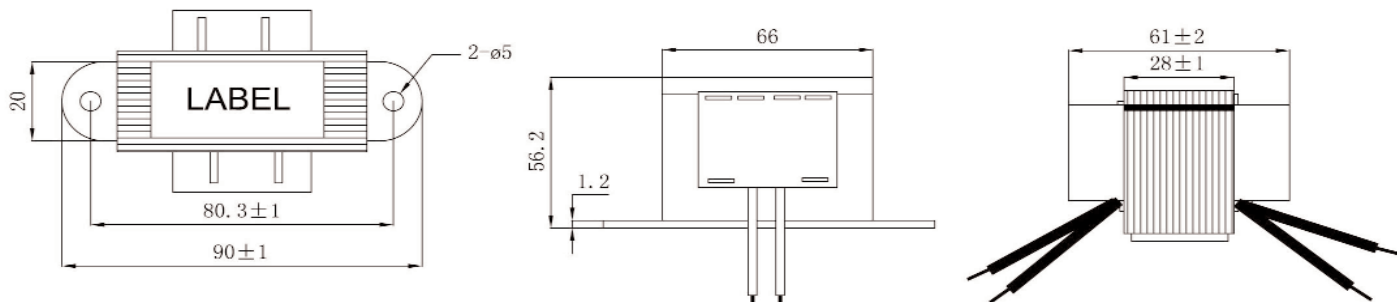

Type FMQ2

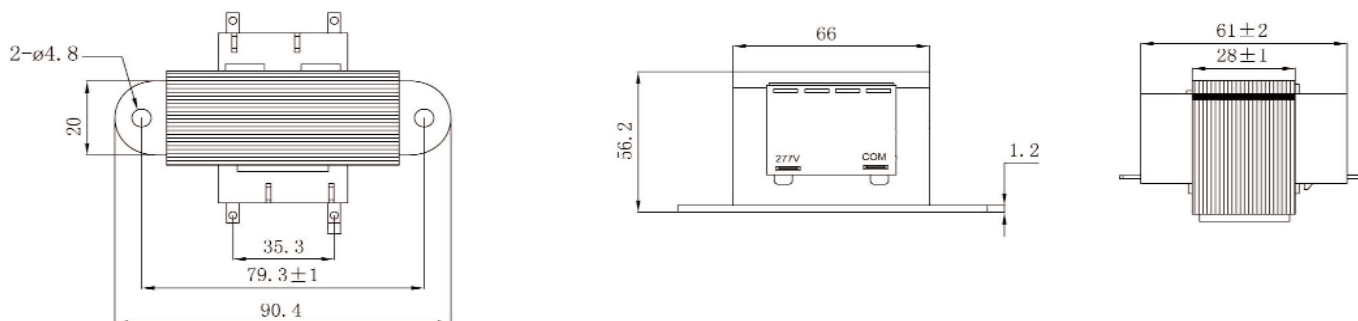

Type FMCW

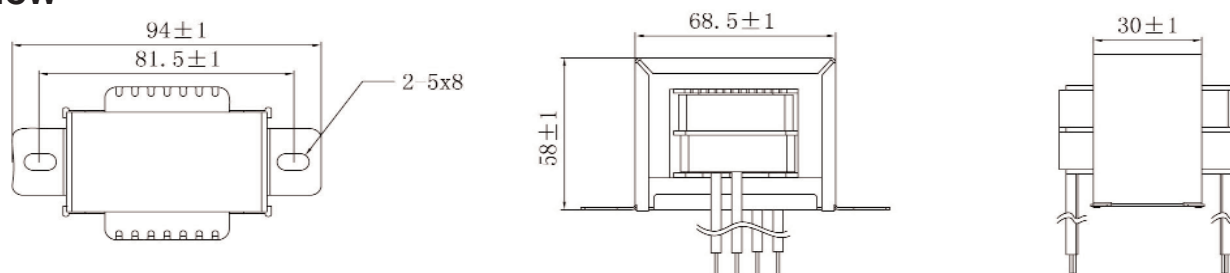

Type FMWX

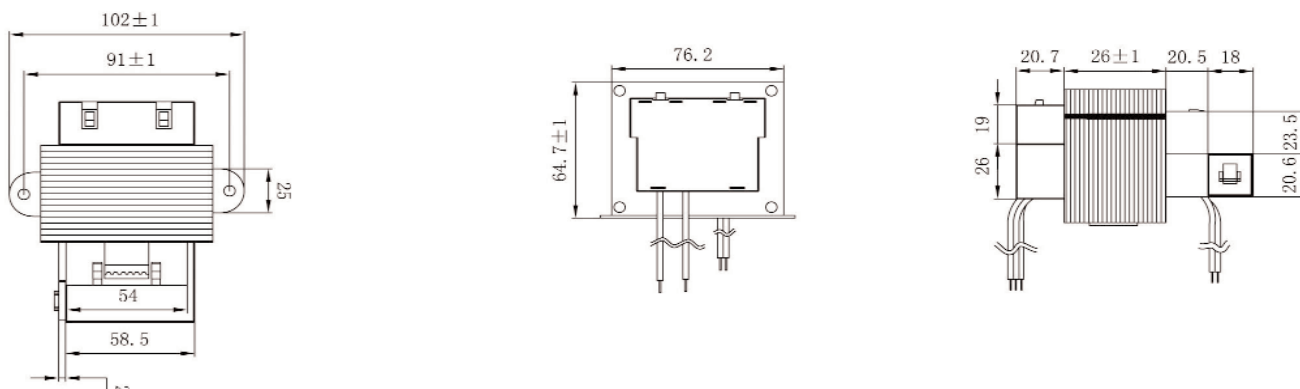

ZETTLER Magnetics, Inc.

75 COLUMBIA • ALISO VIEJO, CA 92656 • PHONE: (949) 360-5838 • FAX: (949) 360-5839 • E-MAIL: SALES@ZETTLERMAGNETICS.COM

ZM AHRV Series

Type FMBAW1X

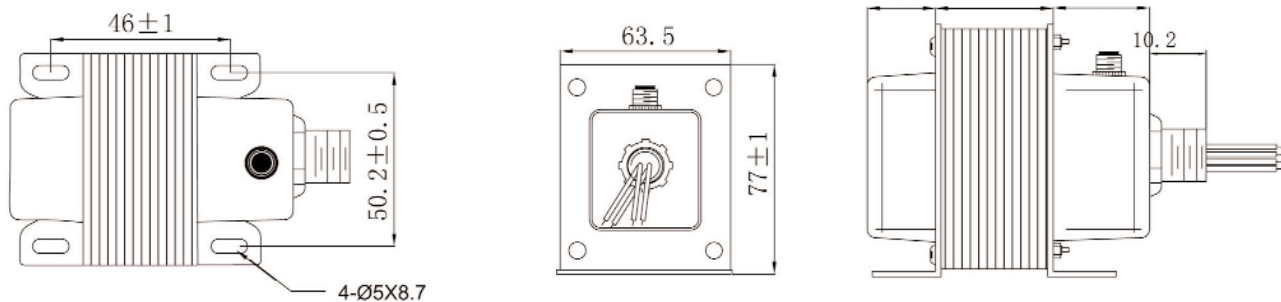

Type MMBQW

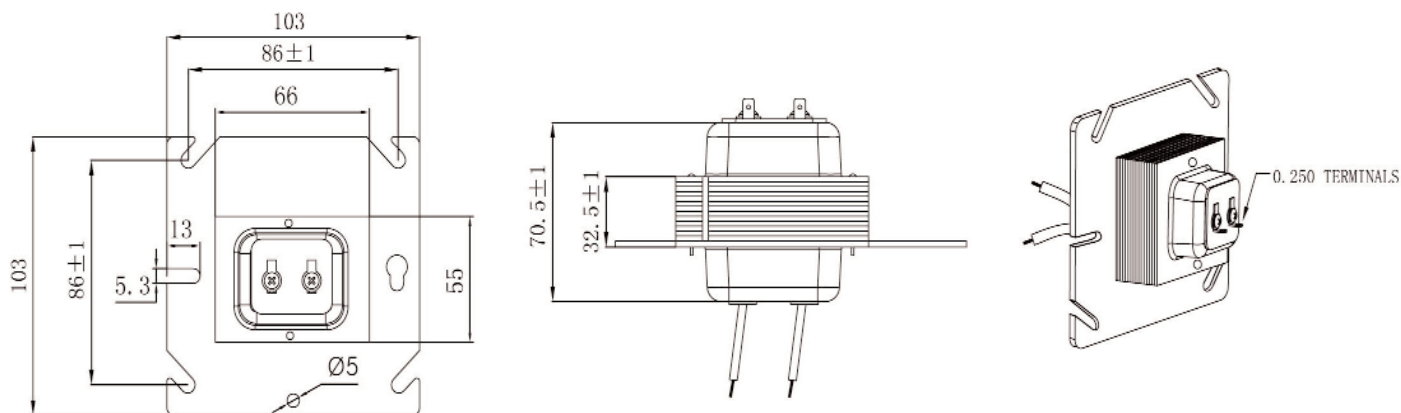

*Contact factory for specific mounting and terminal requirements. Tolerance ± 1 mm unless specified otherwise.



ZETTLER *Magnetics, Inc.*

75 COLUMBIA • ALISO VIEJO, CA 92656 • PHONE: (949) 360-5838 • FAX: (949) 360-5839 • E-MAIL: SALES@ZETTLERMAGNETICS.COM

ZM AHRV Series

60 VA CLASS 2 TRANSFORMERS

Type MMBQW

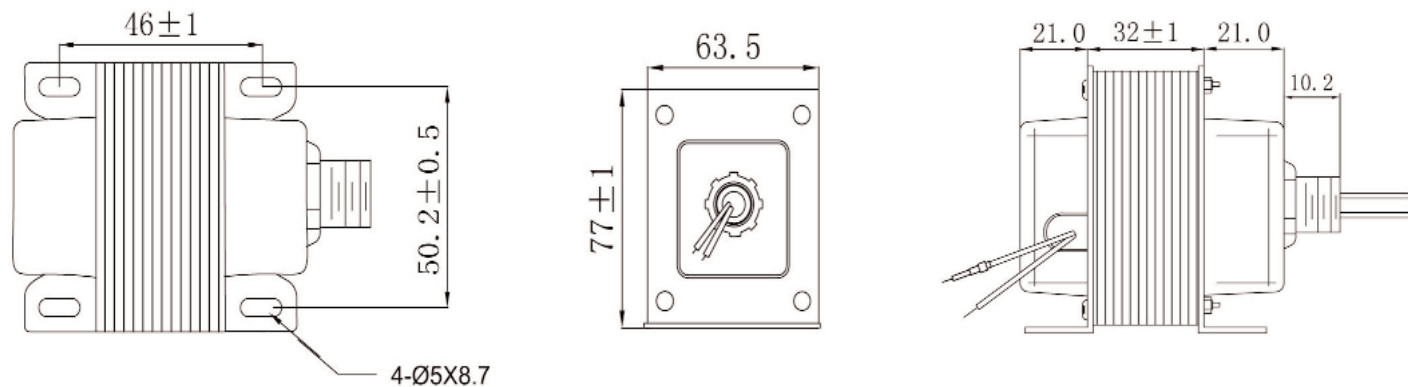

*Contact factory for specific mounting and terminal requirements. Tolerance ± 1mm unless specified otherwise.



ZETTLER *Magnetics, Inc.*

75 COLUMBIA • ALISO VIEJO, CA 92656 • PHONE: (949) 360-5838 • FAX: (949) 360-5839 • E-MAIL: SALES@ZETTLERMAGNETICS.COM

ZM AHRV Series

75 VA CLASS 2 TRANSFORMERS

Type FMW

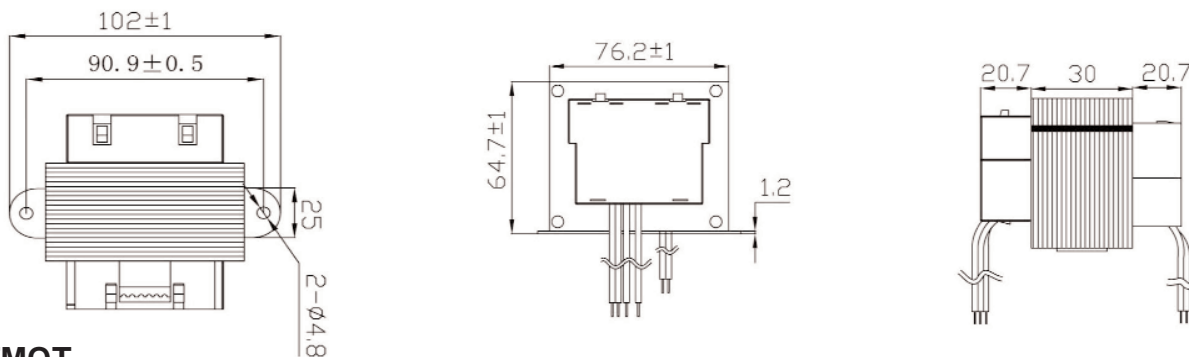

Type FMQT

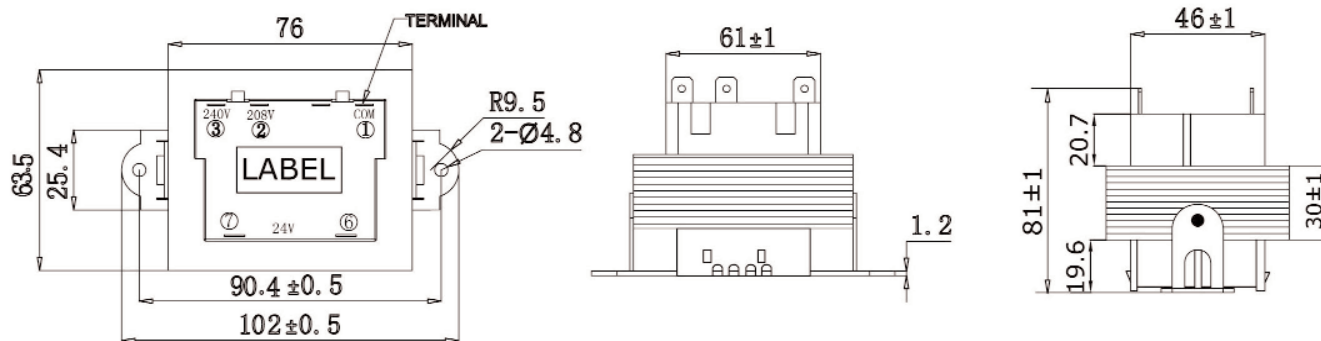

Type FMWX

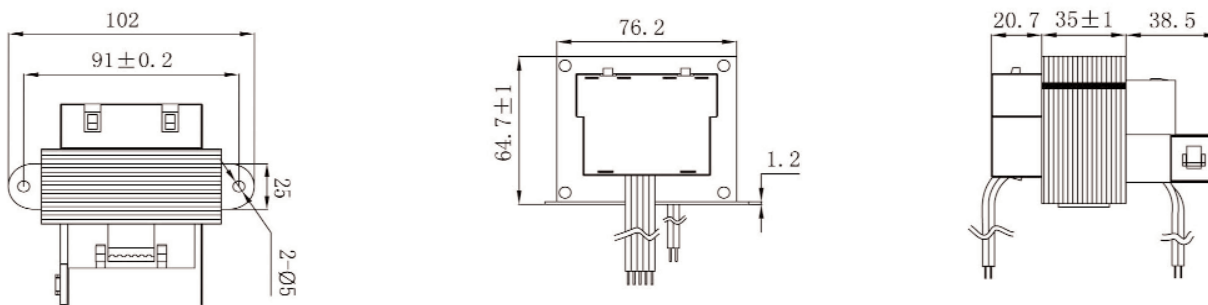

Type FMBAW1X

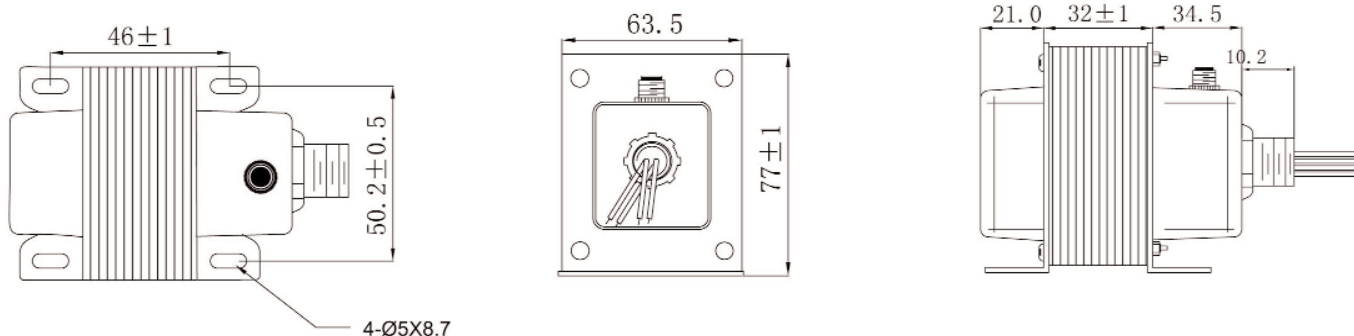

ZETTLER Magnetics, Inc.

75 COLUMBIA • ALISO VIEJO, CA 92656 • PHONE: (949) 360-5838 • FAX: (949) 360-5839 • E-MAIL: SALES@ZETTLERMAGNETICS.COM

ZM AHRV Series

Type FMBBW2X

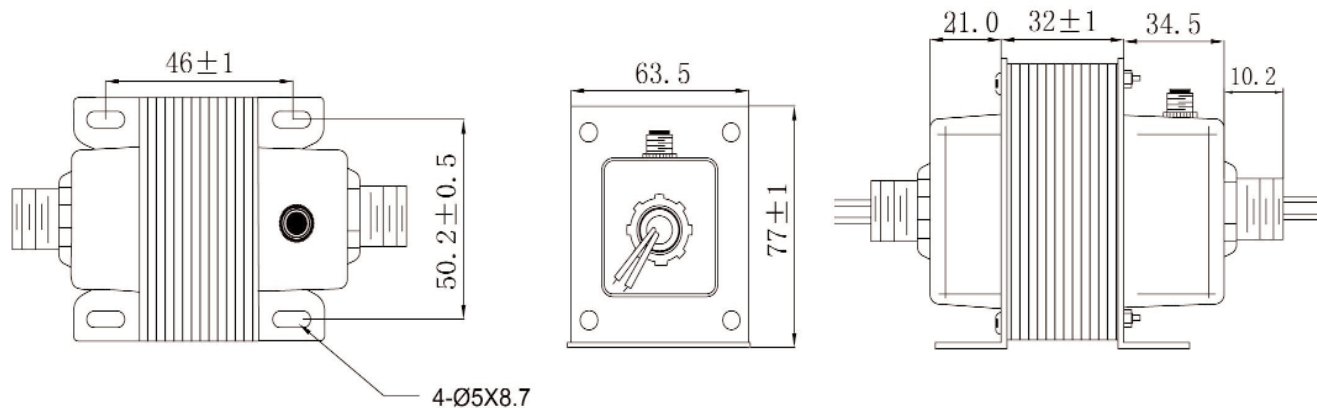

Type FMBCW2X

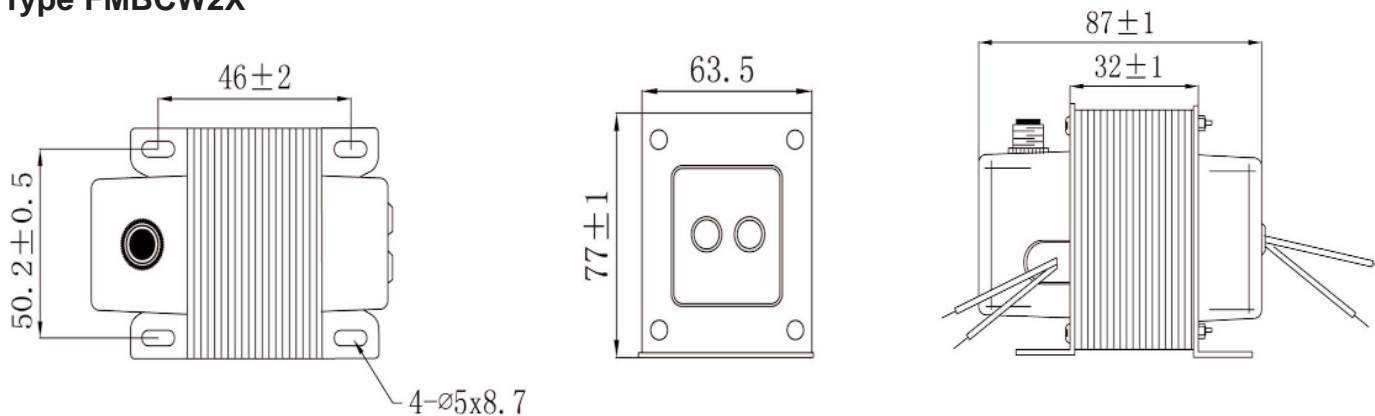

*Contact factory for specific mounting and terminal requirements. Tolerance ± 1 mm unless specified otherwise.



ZETTLER *Magnetics, Inc.*

75 COLUMBIA • ALISO VIEJO, CA 92656 • PHONE: (949) 360-5838 • FAX: (949) 360-5839 • E-MAIL: SALES@ZETTLERMAGNETICS.COM

ZM AHRV Series

96 VA CLASS 2 TRANSFORMERS

Type FMBAW1X

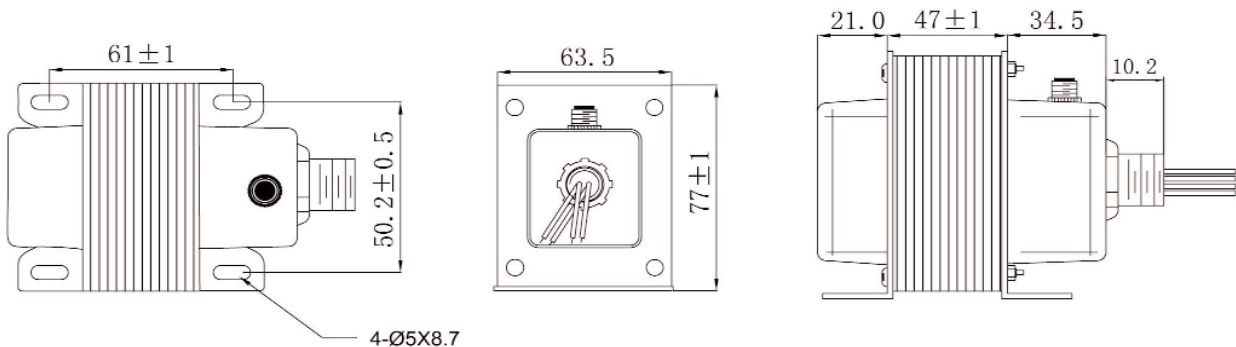

Type FMBBW2X

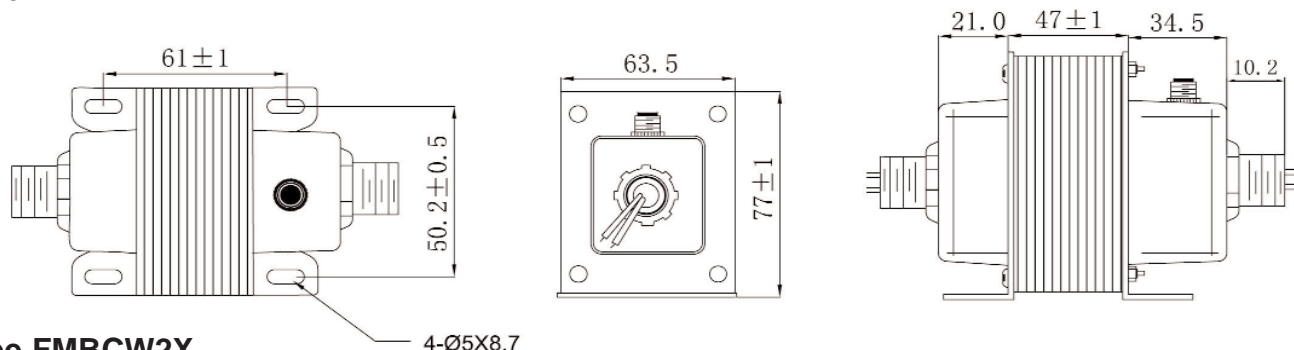

Type FMBCW2X

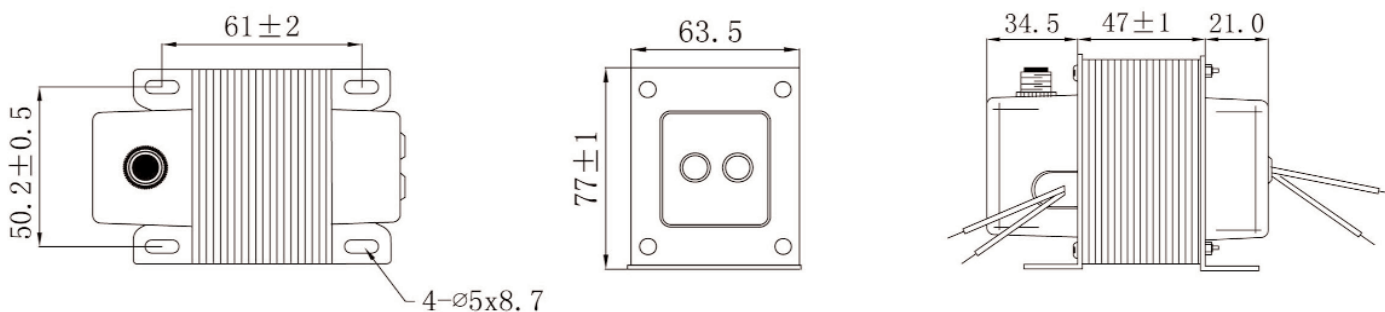

Type FMBDW1X

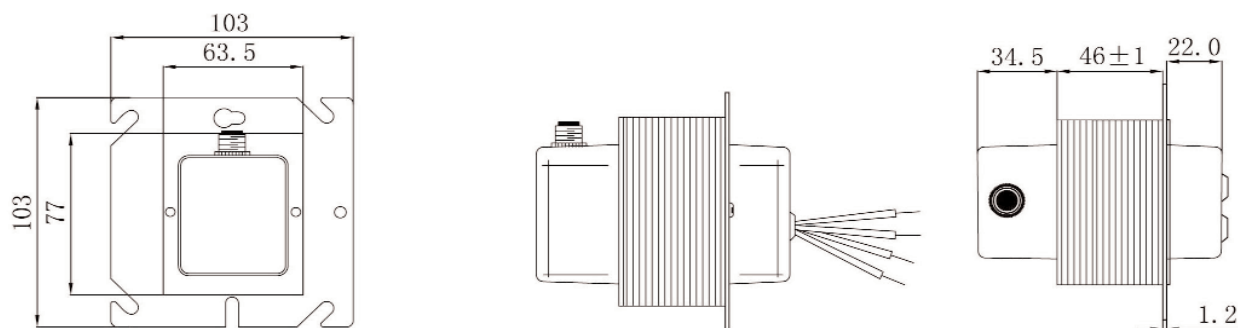

ZETTLER Magnetics, Inc.

75 COLUMBIA • ALISO VIEJO, CA 92656 • PHONE: (949) 360-5838 • FAX: (949) 360-5839 • E-MAIL: SALES@ZETTLERMAGNETICS.COM

ZM AHRV Series

Type FMBEQWX

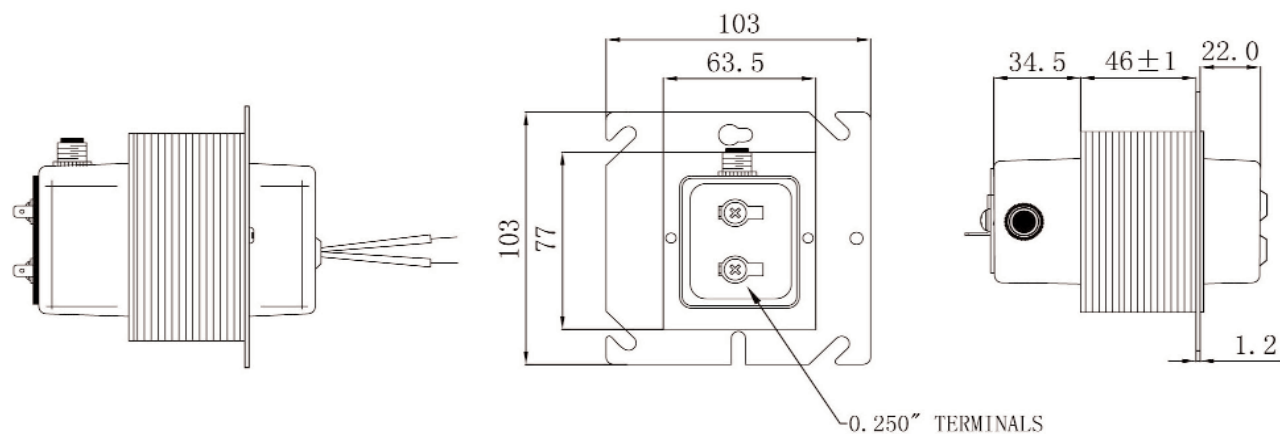

*Contact factory for specific mounting and terminal requirements. Tolerance ± 1mm unless specified otherwise.



ZETTLER *Magnetics, Inc.*

75 COLUMBIA • ALISO VIEJO, CA 92656 • PHONE: (949) 360-5838 • FAX: (949) 360-5839 • E-MAIL: SALES@ZETTLERMAGNETICS.COM